



10623 Roselle Street, San Diego, CA 92121 • (858) 550-9559 • Fax (858) 550-7322  
contactus@accessio.com • www.accessio.com

**MODEL USB3-HUB-7**

**INDUSTRIAL SEVEN PORT USB 3.1 HUB**

**USER MANUAL**

FILE: MUSB3-HUB-7.A1b

### **Notice**

The information in this document is provided for reference only. ACCES does not assume any liability arising out of the application or use of the information or products described herein. This document may contain or reference information and products protected by copyrights or patents and does not convey any license under the patent rights of ACCES, nor the rights of others.

IBM PC, PC/XT, and PC/AT are registered trademarks of the International Business Machines Corporation.

Printed in USA. Copyright by ACCES I/O Products Inc., 10623 Roselle Street, San Diego, CA 92121. All rights reserved.

### **WARNING!!**

**ALWAYS CONNECT AND DISCONNECT YOUR FIELD CABLING WITH THE COMPUTER POWER OFF. ALWAYS TURN COMPUTER POWER OFF BEFORE INSTALLING A CARD. CONNECTING AND DISCONNECTING CABLES, OR INSTALLING CARDS INTO A SYSTEM WITH THE COMPUTER OR FIELD POWER ON MAY CAUSE DAMAGE TO THE I/O CARD AND WILL VOID ALL WARRANTIES, IMPLIED OR EXPRESSED.**

## **Warranty**

Prior to shipment, ACCES equipment is thoroughly inspected and tested to applicable specifications. However, should equipment failure occur, ACCES assures its customers that prompt service and support will be available. All equipment originally manufactured by ACCES which is found to be defective will be repaired or replaced subject to the following considerations.

## **Terms and Conditions**

If a unit is suspected of failure, contact ACCES' Customer Service department. Be prepared to give the unit model number, serial number, and a description of the failure symptom(s). We may suggest some simple tests to confirm the failure. We will assign a Return Material Authorization (RMA) number which must appear on the outer label of the return package. All units/components should be properly packed for handling and returned with freight prepaid to the ACCES designated Service Center, and will be returned to the customer's/user's site freight prepaid and invoiced.

## **Coverage**

First Three Years: Returned unit/part will be repaired and/or replaced at ACCES option with no charge for labor or parts not excluded by warranty. Warranty commences with equipment shipment.

Following Years: Throughout your equipment's lifetime, ACCES stands ready to provide on-site or in-plant service at reasonable rates similar to those of other manufacturers in the industry.

## **Equipment Not Manufactured by ACCES**

Equipment provided but not manufactured by ACCES is warranted and will be repaired according to the terms and conditions of the respective equipment manufacturer's warranty.

## **General**

Under this Warranty, liability of ACCES is limited to replacing, repairing or issuing credit (at ACCES discretion) for any products which are proved to be defective during the warranty period. In no case is ACCES liable for consequential or special damage arising from use or misuse of our product. The customer is responsible for all charges caused by modifications or additions to ACCES equipment not approved in writing by ACCES or, if in ACCES opinion the equipment has been subjected to abnormal use. "Abnormal use" for purposes of this warranty is defined as any use to which the equipment is exposed other than that use specified or intended as evidenced by purchase or sales representation. Other than the above, no other warranty, expressed or implied, shall apply to any and all such equipment furnished or sold by ACCES.

# TABLE OF CONTENTS

Chapter 1: Introduction.....	5
Features	5
Applications	5
Functional Description	5
Ordering Guide	6
Model Options	6
Optional Accessories	6
Included with your USB3-HUB-7	6
Figure 1-1: Block Diagram	7
Figure 1-2: Enclosure Label	7
Chapter 2: Installation .....	8
Software CD Installation	8
Hardware Installation	8
Chapter 3: Hardware Details.....	9
Figure 3-1: Option Selection Map	9
Figure 3-2: USB3-HUB-7 Front Panel	9
USB Connectors	10
LEDs	10
External Power	10
Locking DC Power Jack	10
Non-locking DC Power Jack (economy version)	10
Screw Terminals	10
WI Option	10
Chapter 4: Specifications.....	11
Customer Comments .....	12

## Chapter 1: Introduction

The USB3-HUB-7 is a high performance and low cost solution for rugged, reliable, USB expansion. It is compliant with the USB 3.1 specification as well as being fully backwards compatible with all previous versions of USB. Each of the seven downstream ports are capable of SuperSpeed (SS), Hi-Speed (HS), Full-speed, and Low-Speed transfers.

### Features

- 7-port USB 3.1 Gen 1 hub with data transfers up to 5Gbps
- Rugged, industrial grade (-40°C to 85°C) operation
- Locking USB and power connectors prevent accidental disconnects
- SuperSpeed (5Gbps), Hi-Speed (480Mbps), Full-Speed (12Mbps), and Low-Speed (1.5Mbps) transfers supported
- Supports bus-powered and self-powered modes, accessible via DC power jack or a removable pair of screw terminals
- LED for power, and per port RGB LEDs to indicate overcurrent fault, High-Speed, and SuperSpeed
- Compact, steel, low-profile enclosure
- RoHS compliant

### Applications

- Portable / Laptop
- Education / Laboratory
- Industrial Automation
- Embedded OEM
- Military Systems Expansion

### Functional Description

The USB3-HUB-7 is an industrial-grade 7-port USB hub optimized for harsh and rugged environments. This hub has locking / latching connectors on upstream and downstream ports as well as power, preventing accidental disconnects - making it perfect for applications that require vibration proofing. By using a USB-IF and Windows Hardware Quality Lab (WHQL) certified hub controller, compatibility is assured. The rugged steel enclosure, locking / latching connections, and -40°C to +85°C operation makes the USB3-HUB-7 stand out compared to commercially available hubs.

Each connection has been designed for rugged use without loose or intermittent cables disrupting your application. When externally powered the screw terminal or threaded DC Jack secure the power connection. PEM nuts on the enclosure at the Type B USB connector and jackscrews on the cable secure the upstream connection. Latching Type A ports provide high-retention (50N) downstream connections compatible with all industry-standard USB cables.

The hub supports SuperSpeed (SS), Hi-Speed (HS), Full-Speed, and Low-Speed on all ports. Each downstream port indicator lights Red, Green, or Blue (RGB) to indicate fault, USB2/High-Speed, or USB3/SuperSpeed, respectively. The hub also supports bus-powered and self-powered applications. If downstream peripherals require more current,

the USB3-HUB-7 can be configured in self-powered mode. External +5V can be supplied to the board, which will provide 900mA to each downstream port.

This product is fully protected from faulty peripherals. Each downstream port utilizes a power distribution switch providing overcurrent and short circuit protection. If a fault occurs, the power distribution switch will disable that port and illuminate the LED red. The disabled port can be re-enabled by clearing the fault and cycling power to the port.

The board is designed to be used in rugged industrial environments, but is small enough to fit nicely onto any desk or testing station. The –OEM (board only) is 3.250" by 5.750" while the enclosure is 3.460" x 6.260" x 1.045".

### Ordering Guide

USB3-HUB-7	RoHS compliant industrial USB 3.1 Gen 1 hub with locking/latching connectors in rugged enclosure (includes 6' high-quality USB 3.1 locking cable)
USB3-HUB-7-E	Economy version with standard non-latching power and data connections (includes 6' high-quality USB 3.1 cable)

### Model Options

-OEM	Board only version (no enclosure)
-WI	Requires external power of 6 to 55 VDC
-TAN	Tantalum Caps for high altitude usage (no electrolytics)
-CC	Conformal Coating for use in high humidity and dusty environments

### Optional Accessories

PWR-ACDC-5V5A	External Power Supply
PWR-ACDC-5V5A-L	External Power Supply with locking connector
LF-JDC-PLUG	Locking DC Power Plug w/sturdy backshell and solder tabs
CAB-USB3LL	6' high-quality USB 3.1 cable w/screw locks on A & B ends
MP104-DIN	DIN rail mounting provision

### Included with your USB3-HUB-7

The following components are included in your shipment. Please take the time now to ensure that no items are damaged or missing.

- USB Module in labeled enclosure with an anti-skid bottom
- 6' USB 3.1 cable type A (non-locking) to locking type B (USB3 Vision compatible)

**Figure 1-1: Block Diagram**

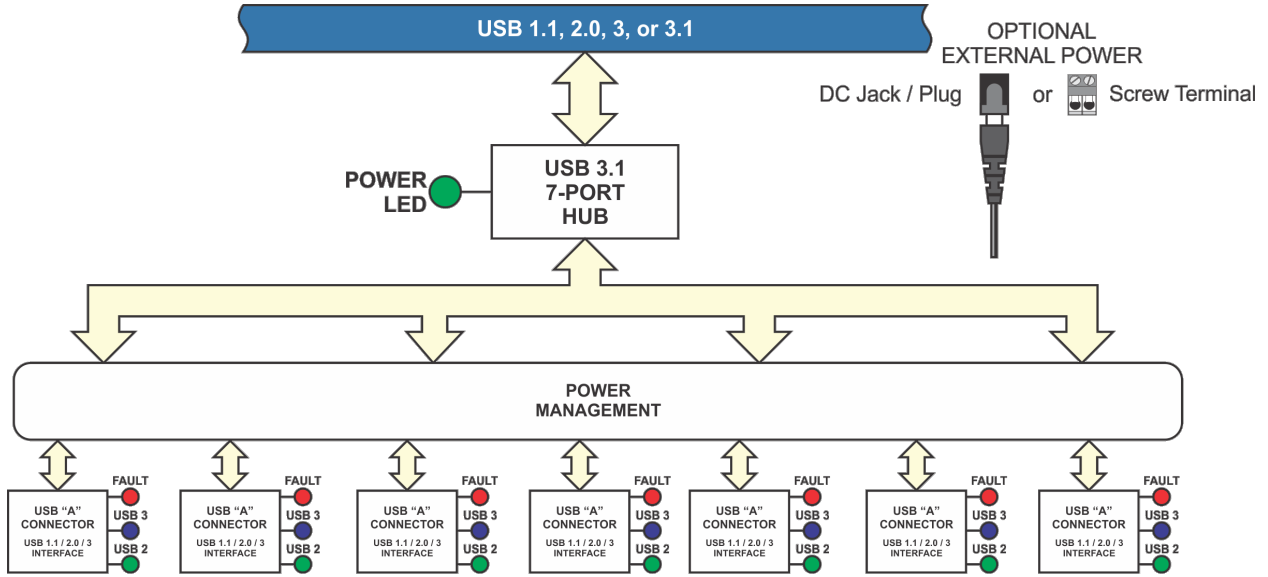

**Figure 1-2: Enclosure Label**

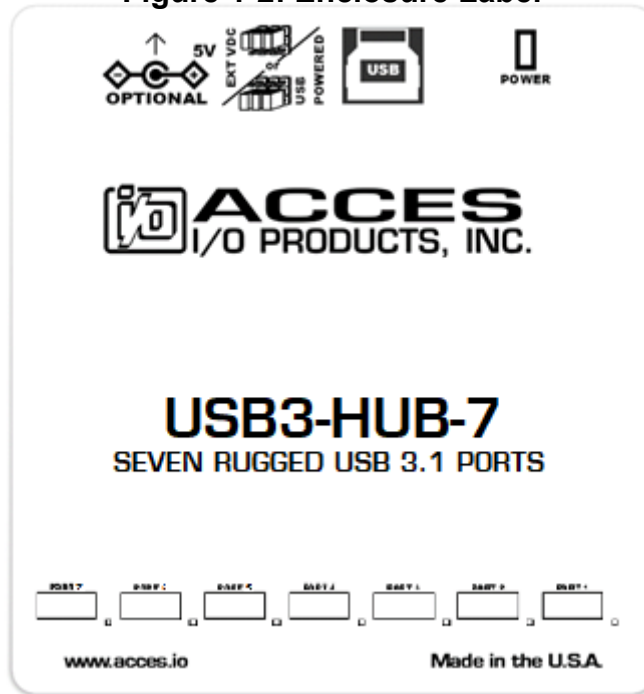

## **Chapter 2: Installation**

### **Software CD Installation**

No software is provided with this board. There is no need to install any drivers for the USB3-HUB-7 product. It will enumerate as a Generic Hub using the USB Hub Class Driver that is built into Windows OS or Linux. There's no driver needed from the user.

### **Hardware Installation**

The unit can be connected to any USB 3.1, 3.0, 2.0 or USB 1.1 port.



## Chapter 3: Hardware Details

Refer to the Block diagram and the Option Selection Map when reading this section of the manual.

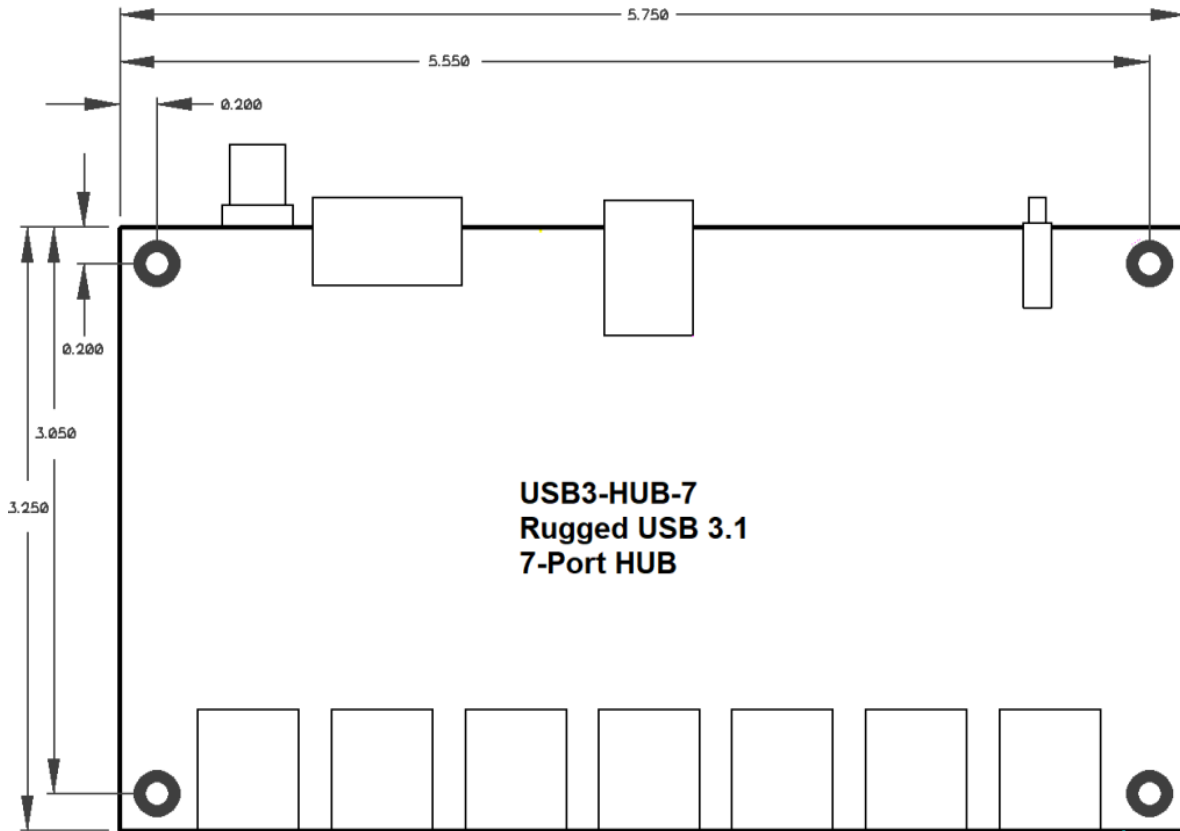

Figure 3-1: Option Selection Map

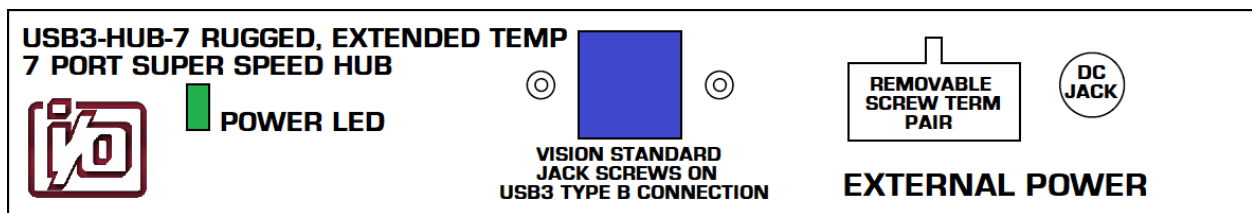

Figure 3-2: USB3-HUB-7 Front Panel

## USB Connectors

The upstream USB connector is a USB 3.1 Type B and connects to the host USB port with a standard “A to B” cable (provided). The host USB port provides communication signals along with +5 VDC power. Downstream USB connectors are latching USB 3.1 Type A (non-latching available as economy version).

## LEDs

A green LED on the front of the enclosure (next to the USB type B connector) is used to indicate power to the board. Seven RGB LEDs are next to the seven downstream Type A connectors.

## External Power

When more current is needed than the upstream USB port can provide there are a few methods available to provide external power.

### Locking DC Power Jack

DC1 is a locking DC jack (Switchcraft RAPC10P) that has a 2.00mm post on board and is designed to be used with our +5 VDC AC/DC external power supply that is optionally available (model PWR-ACDC-5V5A-L).

### Non-locking DC Power Jack (economy version)

DC1 is a standard DC jack that has a 2.00mm post on board and is designed to be used with our +5 VDC AC/DC external power supply that is optionally available.

### Screw Terminals

TB1 is a two-position removable screw terminal block that provides a method for the user to connect the external power +5V and return (GND) without needing to open the hub enclosure. Note that power applied through TB1 must follow the USB specification of providing no more than +5.25V and no less than +4.75V (+5V±5%).

### WI Option

With the “Wide Input” power factory option, provide between 6VDC and 55VDC as external power instead of 5VDC, via the screw terminals, or via the DC jack. We recommend ordering the optional external locking DC plug (LF-JDC-PLUG) to integrate into your system power supply harness.

## Chapter 4: Specifications

Bus Type: USB 3.1 Gen 1 / 2.0 / 1.1  
Super (5Gbps) / Hi (480Mbps) Full (12Mbps) / Low (1.5Mbps)  
Seven Type A downstream ports

### Environmental

Operating & Storage: -40° to +85°C  
Humidity: 5-95% non-condensing  
Board Size: 3.250" × 5.750"  
Enclosure Size: 6.260" × 3.460" × 1.045"  
Weight: 370.8 grams (with enclosure)  
90 grams (-OEM version)

**Cable** 6' USB3 Vision cable Type B with thumbscrews to standard Type A

**Power** No external power *required*

Optional ext. power Connect via screw terminals, a locking DC jack / plug,  
or standard jack / plug

Optional Wide Input -WI, 6 to 55VDC Input

**CAUTION: Must use screw terminal for external power >24V**

USB3.1 Up to 650mA at 5VDC required

Bus Powered Approximately 250 mA available from host for downstream ports; typical  
consumption at idle: 190 mA

Externally Powered 900mA available per downstream port

USB2.0 Up to 200mA at 5VDC required

Bus Powered Approximately 220 mA available from host for downstream ports; typical  
consumption at idle: 110 mA

Externally Powered 500mA available per downstream port

### Connectors

USB Type A Latching Retention up to 50 Newtons  
Physical shock: Per EIA-364-27 Condition H (11ms 30G)  
Vibration: Per EIA-364-28D  
Condition V, Test A

USB Type B & A 8 Newtons disconnect non-locking

DC Jack (locking) Vibration: Method 201A  
(MIL-STD-202G) Ins. Resistance: Method 302 Condition B  
Thermal Shock: Method 107G  
Temperature: -40-105°C (-40-+221°F)

DC Jack (non-locking) 2.22 Newtons disconnect

### Note: USB 3.1 vs USB 3.0 ... vs USB 3.2

USB 3.0 was renamed to "USB 3.1 Gen 1" and operates at up to 5Gbps

USB 3.1 Gen 2 supports 10Gbps

USB 3.1 was renamed USB 3.2; "Gen 1" and "Gen 2" retain their meanings.



## Customer Comments

If you experience any problems with this manual or just want to give us some feedback, please email us at: ***manuals@accessio.com***. Please detail any errors you find and include your mailing address so that we can send you any manual updates.



10623 Roselle Street, San Diego CA 92121-1506  
Tel. (858) 550-9559  
accessio.com