

FEATURES

MODEL M.2-ADIO16-8F

- M.2 TYPE 2280/2260, WITH LATCHING I/O CONNECTOR
- 16-BIT, BIPOLAR, DIFFERENTIAL, A/D CONVERTER
 - SOFTWARE SELECTABLE AS 8 SINGLE-ENDED (PSEUDO-DIFFERENTIAL) OR 4 DIFFERENTIAL INPUTS
 - 7 CHANNEL-BY-CHANNEL PROGRAMMABLE DIFFERENTIAL INPUT RANGES FROM $\pm 0.3125V$ UP TO $\pm 12V$
 - SUSTAINED SAMPLING RATES UP TO 1MHZ
 - A/D STARTS VIA SOFTWARE, EXTERNAL INPUT, OR PERIODIC TIMER
 - A/D "SCAN START" MODE OPTIMIZES INTER-CHANNEL TIMING
 - HIGH IMPEDANCE, 8-CHANNEL INPUT: 500 M Ω
 - 32K FIFO PLUS DMA FOR EFFICIENT, ROBUST DATA STREAMING
- FOUR 16-BIT ANALOG OUTPUTS
 - 5 PER-CHANNEL PROGRAMMABLE RANGES: 0V TO 5V, 0V TO 10V, $\pm 2.5V$, $\pm 5V$, $\pm 10V$
 - OUTPUTS DRIVE $\pm 10mA$ GUARANTEED
- 16 DIGITAL I/O; 8 INDIVIDUALLY CONFIGURABLE FOR INPUT/OUTPUT
- ONBOARD WATCHDOG WITH STATUS OUTPUT
- ROHS COMPLIANT STANDARD

FACTORY OPTIONS INCLUDE

- CURRENT INPUT (4-20MA, 10-50MA)
- VOLTAGE DIVIDERS PER INPUT
- EXTENDED TEMP OPERATION

FUNCTIONAL DESCRIPTION

The M.2-ADIO16-8F is an ideal solution for adding high-speed analog I/O capabilities to any computer with an mPCIe slot.

The M.2-ADIO16-8F is a 16-bit resolution A/D & D/A card with a 1MHz A/D converter, having a total of either 8 single ended or 4 differential analog inputs. Each channel can be independently software configured to accept any of 7 input ranges. Four analog outputs with 5, 10, ± 5 , ± 10 , and $\pm 2.5V$ ranges are provided. 16 Digital I/O bits feature advanced functionality including IRQ generation, External DAC Load, ADC Trigger, and ADC Start, as well as Watchdog Status output.

This tiny analog I/O card provides the user with everything needed to start acquiring and controlling signals in a variety of applications. The M.2-ADIO16-8F data acquisition board can be used in many current real-world applications such as embedded equipment monitoring, precision PC-based and portable environmental measurements, and mobile data acquisition. The card is designed to be used in rugged industrial environments and is a double sided "F1" sized PCI Express Mini Card.

Applications: Optical Networking, Instrumentation, Multichannel Data Acquisition and system monitoring, Automatic Test Equipment, Process Control and Industrial Automation, Power line monitoring.

SOFTWARE

The card is supported for use in most operating systems and includes a free Linux and Windows compatible software package. This package contains sample programs and source code in C# and Delphi for Windows. Also provided is a graphical setup program in Windows. Linux support includes installation files and basic samples for programming from user level via an open source kernel driver. Third party support includes a Windows standard DLL interface usable from the most popular application programs. Embedded OS support includes the family of Windows Operating Systems including IoT. ACCES is also now offering a VxWorks driver/library for the ultimate real-time process monitoring and control solution.

SPECIAL ORDER

Please contact ACCES with your precise requirement. Examples of special orders would be conformal coating, custom software, custom product labeling, 5-100mA input support, per-channel input-voltage dividers, and more. We will work with you to provide *exactly* what is required.

AVAILABLE ACCESSORIES INCLUDE

CAB-M.2-ADIO	Board to DB37M 9" twisted pair cable accessory
M.2-HDW-KIT2	Mounting hardware for 2mm
M.2-HDW-KIT2.5	Mounting hardware for 2.5mm
ADAP37F-MINI	Direct plug-on terminal board mates with DB37M on CAB-M.2-ADIO
LF-BRK-P9259-37	Mounting bracket for DB37M on CAB-M.2-ADIO

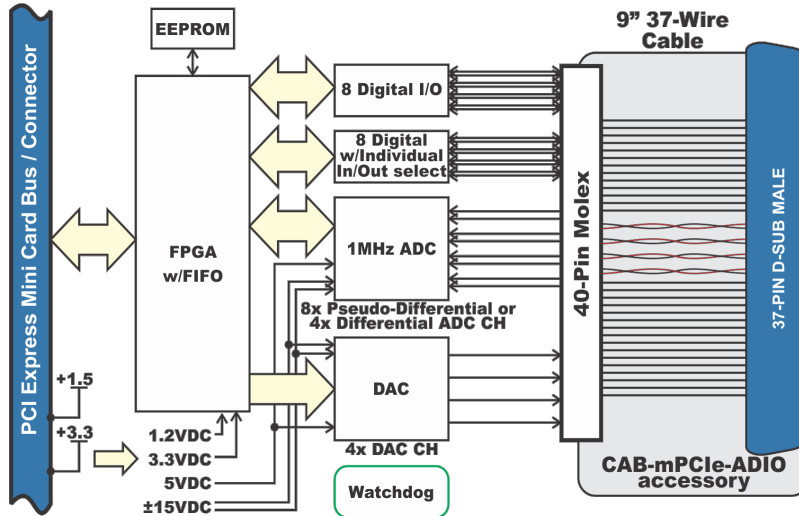

PC Interface

M.2 type	2280 with breakaway to convert to 2260
----------	--

Analog Inputs

ADC Type	Successive approximation
Resolution	16-bit differential bipolar ADC
Sampling rate	1 Msps aggregate
Number of channels	8 Single-ended or 4 Differential (software selectable)
Differential Bipolar Ranges (V)	$\pm 12, \pm 10, \pm 5, \pm 2.5, \pm 1.25, \pm 0.625, \pm 0.3125$ V with 0, 0, $\pm 5.12, \pm 7.68, \pm 8.96, \pm 9.60, \pm 9.92$ V common mode rejection, respectively
4-20mA or 10-50mA	Factory options
Int Nonlinearity Error	± 0.6 LSB to ± 1.5 LSB depending on gain
No Missing Codes	16 bits
Input Impedance	>500 M Ω
A/D Start Sources	Software Start, Timer Start, External Start, Externally Triggered Timer Start
A/D Start Types	Single Channel or Scan
Overvoltage Protection	Current limiting through 2 K Ω
Crosstalk	-120 dB @ 10kHz

Analog Outputs

Number	4
Type:	Single-ended
Resolution:	16-bit
Bipolar Ranges:	± 2.5 V, ± 5 V, ± 10 V
Unipolar Ranges:	0-5 V, 0-10 V
Settling Time	20 μ s typical, ± 10 V (± 1 LSB at 16 bits)
Output Current	max ± 10 mA per channel

Digital Input / Output Interface

Digital Bits	16
Performance	1 μ s per transaction max ~ 3.5 μ s in Windows
Digital Inputs (Standard Version)	Logic High 2.0 V to VCCIO (3.3V DC, 5 VDC tolerant) Logic Low 0 V to 0.8 V
Digital Outputs (Standard Version)	Logic High 2.0 V (min) 24 mA source Logic Low 0.55 V (max) 24 mA sink Power Output +3.3 VDC via 0.5 A polyfuse (resetting)
Digital Inputs w/user VCCIO (-VCCIO Option)	74LVC8T245 Buffer chip bits 0-7 74LVC8T145 Buffer chip bits 8-15 (individual direction) Logic High 3.5 V to 5 V, UVCCIO = 5 V Logic Low 0 V to 1.5 V, UVCCIO = 5 V

Digital Outputs w/user VCCIO (-VCCIO Option)	1.65 V to 5.5 V At DB37M, via polyfuse Logic High 3.8 V (min) 32 mA UVCCIO = 4.5 V Logic Low 0.55 V (max) 32 mA UVCCIO = 4.5 V
--	--

Environmental

Temperature	Operating	0°C to +70°C -40°C to +85°C (-T option)
	Storage	-40°C to +105°C
Humidity		5% to 95% RH, non-condensing
Dimensions	Length	80 mm; breakaway to 60 mm
	Width	22 mm
Weight		6.2 g

Power

Power required (from M.2 Bus)	+3.3VDC @ 460mA (idle) 575mA (full load)
-------------------------------	--

I/O Interface Connectors

On card	Molex 501190-4017 40-pin latching
Mating	Molex 501189-4010
On-cable	Male, D-Sub Miniature, 37-pin
Mating	Female, D-Sub Miniature, 37-pin

Model Options

-T	Extended Temperature Operation (-40° to +85°C)
-I or -ID	4-20mA inputs (single-ended or differential)
-VCCIO	User-supplied digital I/O VCC
-Sxx	Special configurations (10-50mA inputs, input voltage dividers, conformal coating, etc.)

Ordering Guide

M.2-ADIO16-8F	M.2, A/D 16-bit, 8-ch, 1MHZ, 4 D/A
M.2-ADIO16-8A	M.2, A/D 16-bit, 8-ch, 500KHZ, 4 D/A
M.2-ADIO16-8E	M.2, A/D 16-bit, 8-ch, 250KHZ, 4 D/A
M.2-ADI16-8F	M.2, A/D 16-bit, 8-ch, 1MHZ
M.2-ADI16-8A	M.2, A/D 16-bit, 8-ch, 500KHZ
M.2-ADI16-8E	M.2, A/D 16-bit, 8-ch, 250KHZ
M.2-ADIO12-8A	M.2, A/D 12-bit, 8-ch, 500KHZ, 4 D/A
M.2-ADIO12-8	M.2, A/D 12-bit, 8-ch, 250KHZ, 4 D/A
M.2-ADIO12-8E	M.2, A/D 12-bit, 8-ch, 100KHZ, 4 D/A
M.2-ADI12-8A	M.2, A/D 12-bit, 8-ch, 500KHZ
M.2-ADI12-8	M.2, A/D 12-bit, 8-ch, 250KHZ
M.2-ADI12-8E	M.2, A/D 12-bit, 8-ch, 100KHZ
CAB-M.2-ADIO	9 inch panel-mount DB37M twisted pair cable assembly